



## TECHNICAL REPORT

**VEII Viking Explorer II  
Long Beach City College  
Long Beach, CA**

<b>Bryan Bischoff</b>	<b>Electrical Technology</b>
<b>Francisco Canul</b>	<b>Electrical Technology</b>
<b>AJ Catalano</b>	<b>Electrical Technology</b>
<b>Francisco Duran</b>	<b>Electrical Technology</b>
<b>Brian Gauthier</b>	<b>Marine Biology</b>
<b>Mike Golebiewski</b>	<b>Electrical Technology</b>
<b>Mike Long</b>	<b>Marine Biology</b>
<b>Matt McCall</b>	<b>Electrical Technology</b>
<b>Saroeun Meas</b>	<b>Electrical Technology</b>
<b>Joe Pham</b>	<b>Auto Mechanics</b>
<b>Jose Saldana</b>	<b>Electrical Technology</b>
<b>Van Yean</b>	<b>Electrical Technology</b>

**Instructor: Scott Fraser  
Advisor: Leonard Fellman**



# Abstract

The VEII Remotely Operated Vehicle (ROV) is an industrial grade apparatus designed to withstand the abuse and extremes of extraterrestrial environments. Fabricated of anodized aluminum extrusion, rugged fiberglass floatation, and pressure tested to 7kg-force/cm<sup>2</sup>; it will survive the harshest situations. It is 58cm long x 57cm wide x 78cm high. It displaces 36.91 liters and weighs 44 kg. With the addition of 7 liters of flotation, the ROV is neutrally buoyant. There are 4 thrusters, an array of science instrumentation including a digital temperature sensor, a sampler, and 4 Ethernet controlled cameras. It is controlled over fiber optic Ethernet link, operates on 48 volts dc and utilizes helium for pneumatics power. Four variable buoyancy chambers provide up to 6kg of lift. The tether provides both electrical and pneumatic power and an exhaust path for the waste helium. The tether also has variable buoyancy by inflating the internal polyvinyl tube housing the power. The tether is cased in a constricting nylon sleeve to keep everything in a tight and uniform package. This is one tough ROV.

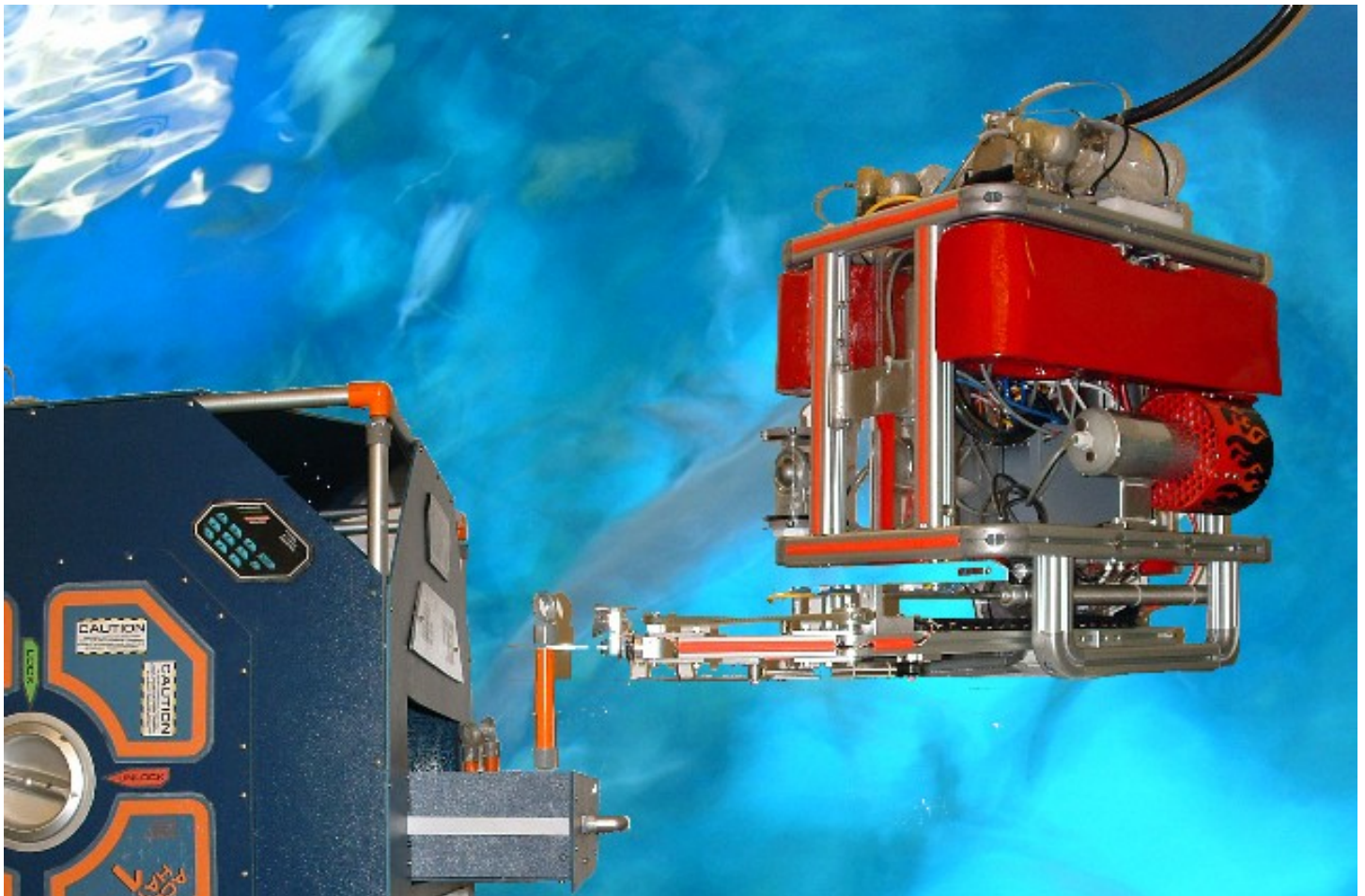

### Design rationale.

*Water Dynamics:* Last year's Viking Explorer ROV was designed in a limited amount of time for the tasks given. Issues such as water dynamics and size were not a high priority. This year with the VEII (the modified Viking Explorer) there was much more time to discuss these issues. Our first change was to downsize the ROV to fit within the constraints of the new scenario. We created new mounts for the horizontal thrusters and brought them in approximately 110mm. The old gripper also had to be removed to accommodate the size limits. Once we solved the issue of size we tackled water dynamics. Rather than leaving the vertical thrusters mounted by L brackets to extrusions, we chose to make thin T mounts that could be welded to one side of a thruster. This cleared about 35% of the path for water to flow. We then slid an acrylic cylinder around each of the vertical thrusters to straighten the water path. For the horizontal thrusters we moved the mounts to new locations out of the water path.

Then we hit our biggest improvement! We discovered a honeycomb grill design on the internet that was being used for improving thrust on tug boats. After discussions with the Innerspace Corporation, they provided us with a set of dimensions to design our own honeycomb grills. These grills were honeycomb shaped to straighten the flow of water. The blades were shaped similar to wings with a sharp side and a blunt side to speed up the exiting water. The grill was designed in SolidWorks by our team and built using a procedure called stereo lithography. In smoke testing we observed a significant difference with the added grills. Without the grills the exhaust smoke swirled outward creating a one meter wide vortex and we actually observed currents back feeding into the thruster. With the grills applied the swirling vortex was corrected to form a perfect column 0.2 meters in diameter and over 2 meters long. All current was straight and uniform. And the smoke was visible at 3x the distance from the thruster. This was a great improvement and success for the VEII.

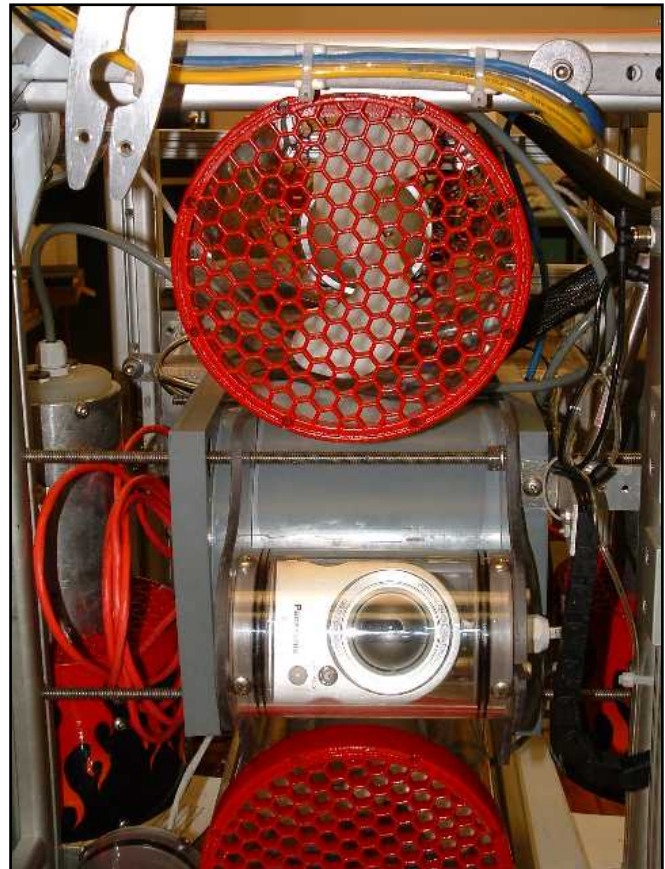

**Figure 1 Bottom of ROV Showing Screens**

*Variable Buoyancy:* This year we decided that variable buoyancy was going to be a necessity. With 3 data probes and 500ml of sampled fluid to bring to the surface, there was a big need to be able to adjust for that weight. Our first idea was to put inner tubes around the two vertical thrusters which would be inflated. We realized that this took up too much space and would be hard to mount. We then decided to build 4 chambers into the ROV's two floats. Each chamber displaces approximately 1.5 liters. This gives the ROV 6 liters of displacement or 6kg of lifting ability. The chambers are inflated in pairs (front and rear) then flooded individually with 4 solenoid valves (also built into the float). Using SolidWorks to create a graphic model, we were able to calculate the exact displacement required to reach neutral buoyancy. Based on these models we created 2 floats which fit perfectly onto the ROV with no intrusion on water flow.

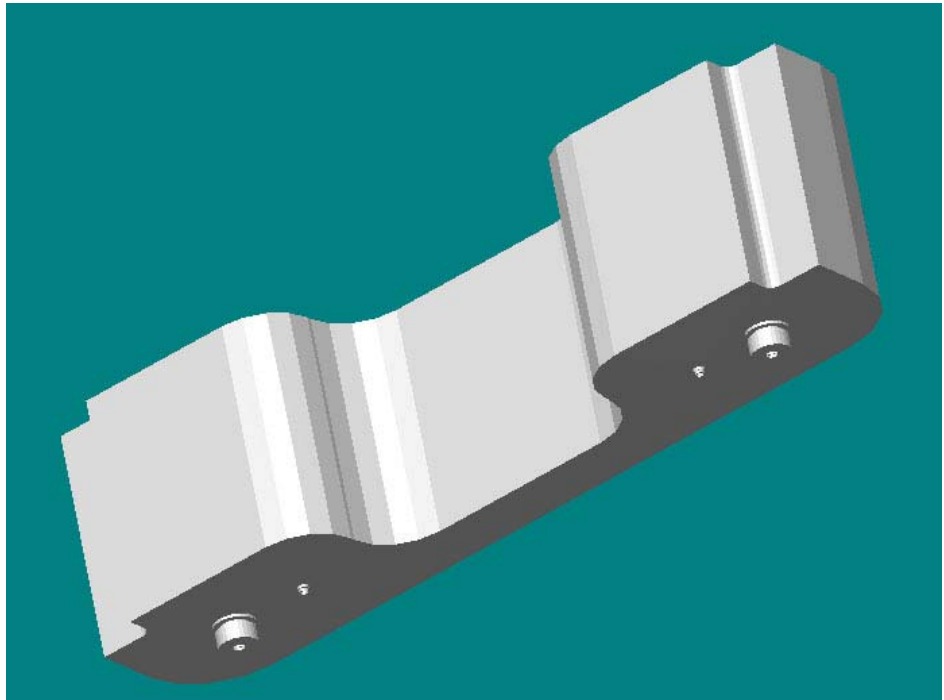

**Figure 2 SolidWorks Rendering of Float Half**



**Figure 3 Side of ROV with Pneumatics Enclosure**

*Pneumatics.* Once it was determined that we would use pneumatics on the ROV, a new design issue appeared and that was what type of gas we should utilize. First thoughts were to use a storage tank and an air compressor. Other ideas included compressed air in a scuba tank, compressed nitrogen and compressed helium. The air compressor and storage tank were quickly eliminated. We realized that the compressed air had the potential to have high moisture content. Without sufficient drying capacity, there was the possibility that we would actually be pumping small amounts of water down to the ROV. The

second choice was then compressed nitrogen. This seemed like a natural. We could fill a tank

almost anywhere and nitrogen is both dry and inert. We then discovered that helium has almost 6 times the thermal transfer capacity of nitrogen. Since we are using our electronics enclosure as a supply plenum, movement of the air through the enclosure would also serve to cool the ROV. We had tested the ROV in water temperatures as high as 25C without problem, but were still concerned about conditions at NASA's NBL with a water temperature up to 31C. The decision was then made to go with helium. It was felt that this would be our best option to provide extra cooling. Finally, in our pneumatics valve enclosure, we have one extra valve with the output routed to the exhaust. This provides us with a direct method of purging the enclosure without operating any of the cylinders.

*Cameras & Lighting and their placement:* The decision of where to place the cameras was based on the ability of the cameras to operate to their fullest extent for maximum viewing. Each camera can pan and tilt approximately  $\pm 50^\circ$  left and right from the home point,  $-50^\circ$  going downwards from the home point, and  $+10^\circ$  going upwards from the home position. This allows us a great deal of visual area. We placed one camera looking forward at the gripper area, one in the rear looking backward, one on top looking up and finally one on the bottom of the ROV looking down and slightly forward. As for the lighting placement, we felt that since we are simulating an exploration within the depths of Europa, we should provide lighting for our cameras without causing glare or any other obstructions to the viewer. So with this in mind we

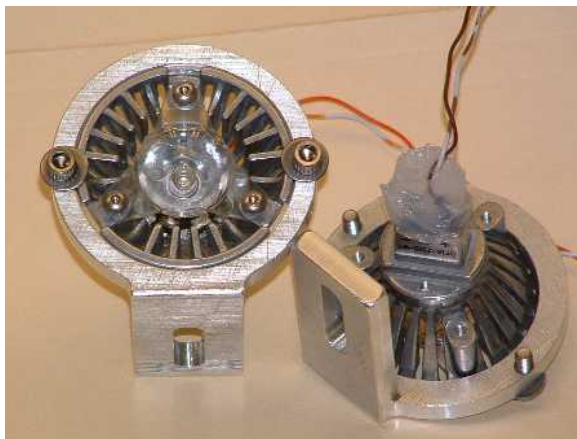

**Figure 4 Luxeon Single LED Lamps**

decided to place the lights in areas that we would need to see such as: where we were going, what we just passed, what's waiting for us in the depths of an uncharted moon, one for aligning and positioning the gripper, and of course one light on top for exiting through the hole in the icy surface. These lights and their placement came from necessity which we found out when we went to the Aquarium of the Pacific while navigating in the depths of the Tropical Reef exhibit. The water dims what little light breaks through the surface and without a light source of our own, it was difficult to navigate through the water without coming too close to the reef and coral bed. It was important to us not to bump into the reef or damage any

decided to place the lights in areas that we would need to see such as: where we were going, what we just passed, what's waiting for us in the depths of an uncharted moon, one for aligning and positioning the gripper, and of course one light on top for exiting through the hole in the icy surface. These lights and their placement came from necessity which we found out when we went to the Aquarium of the Pacific while navigating in the depths of the Tropical Reef exhibit. The water dims what little light breaks through the surface and without a light source of our own, it was difficult to navigate through the water without coming too close to the reef and coral bed. It was important to us not to bump into the reef or damage any



**Figure 5 Bottom of ROV Showing Rear Cam**

structures. The low light limited us to how wide of an area and how close we could get to the reef.

*Sampling – Temperature and Fluid:* The temperature and fluid sampling tasks were integrated into an arm that ends up having three purposes.

1. Holding the fluid sampling probe
2. Holding the temperature sampling probe
3. Functioning as an arm/hand to grab the science package drawer and enable it to be pulled out.

The sampling probe is constructed of two brass tubes, one inside the other with the outside tube being 1cm diameter. The outside of the tube is fitted with a piece of surgical tubing which is used to seal the sample port inlet. The sample probe is designed with an air supply traveling into the large tube and is used to expand the surgical tubing. Down the center of the large tube is a smaller brass tube that actually retrieves the sample once the inlet is sealed.

At the top of the ROV are two 1L sample bottles that complete the sampling system. The actual sampling is performed by first maneuvering the probe into the sample port. The seal is then made by pumping air into the “balloon”. Next, the valve on the priming bottle is opened. This allows fluid to start up the sampling tube, past the camera view and into the primer bottle. Once the camera shows that the fluid had changed colors, the sample bottle can be opened and the primer bottle closed. Finally, the sample bottle will fill until the camera shows that it is at least to the half way point. The physics behind our sampling system is simple pressure differentials. A slight vacuum is pulled in each of the bottles before the mission and we let the pressure differentials do rest of the work.

The temperature probe is a Maxim DS1626 digital temperature chip. It is factory calibrated and accurate to  $\pm 0.5^{\circ}\text{C}$  over its entire temperature range. The chip connects to the control processor through the Serial Peripheral Interface (SPI) and provides the controller with 3 samples per second. The digital chip was used over thermocouple and thermistor methods due to the chips accuracy and elimination of system errors that need to be accounted for in analog systems.

The arm that both of these probes are attached is operated by a pneumatic cylinder and pops out into position for sampling. Once open the arm can also be used to grab the Science Package drawer and help pull it open.



**Figure 6 Front of ROV Showing Sampling Arm**

*Voltage Drop Considerations* – The control electronics and the thrusters on the VEII ROV operate off of 24VDC. The tether is 27 meters long and under full load, we measured a voltage drop of 8 volts using two of the 12 AWG wires in the tether. This means the thrusters were operating at a reduced voltage of 16 volts. In looking at ways to reduce the voltage drop, we first doubled up the wires and added in the other two 12 AWG wires that were already in the tether but not being used. We then realized that we could use 48V and if we found converters of the proper size we wouldn't have to worry about voltage drop problems. We found two very small DC/DC converters. A 48V to 24V (20.8 amps) 500 watt converter and a 48V to 12V (4 amps) 50 watt converter were designed into the system. The 500W converter is called a “full brick” converter and measures 6cm x 11.5cm x 1cm. The 50W converter measures 6cm x 6cm x 1cm. These operate between input ranges of 36V to 75V and provide the thrusters with a regulated 24V regardless of voltage drop. Our calculations now show that we could double the tether length and still function with 48V.



**Figure 7 +48V to 24V 500W Power Supply**

*Communications:* Simply stated, Ethernet and Fiber Optics. By replacing all of the individual video cables with a fiber optic cable, we are able to route all of our signals between the ROV and surface through an “off-the-shelf” standard interface. Ethernet provides error correction and transparent handling of all the data transfers. By using fiber optic as the transfer medium, we also increase the noise immunity and reduce the possibility of errors in our data. Down inside the ROV, we have an eight port 100Mbit switch that all of our communication devices plug into. When everything is plugged in, we have one extra port available for a future high resolution camera.



**Figure 8 Ethernet Communications in ROV**

The Serial link between the Flybox (our joystick control station) and the ROV is performed by two Ethernet to serial Telnet devices. They transparently establish a Telnet connection and provide a transfer path for our control signals. The cameras are all Ethernet cameras with controls and video over the interface. Finally, our telemetry is provided by an embedded Web Server located inside the ROV. The ROV controller sends telemetry values over a serial link to the Web Server and then formatted telemetry pages are served up on demand to the control station.

All of this will provide us with the capability in the future to provide remote access opportunities for local schools or anyone around the world with an internet connection.

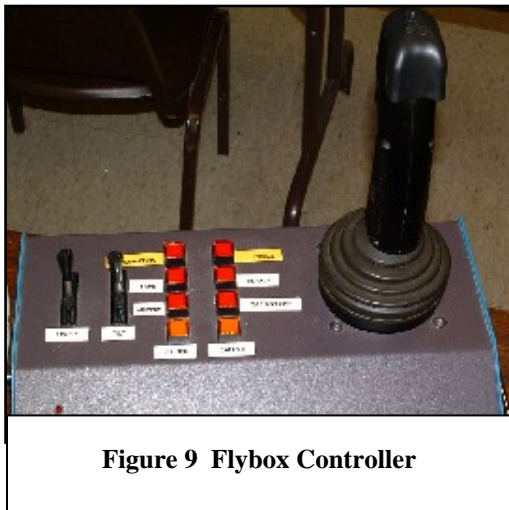

**Figure 9 Flybox Controller**

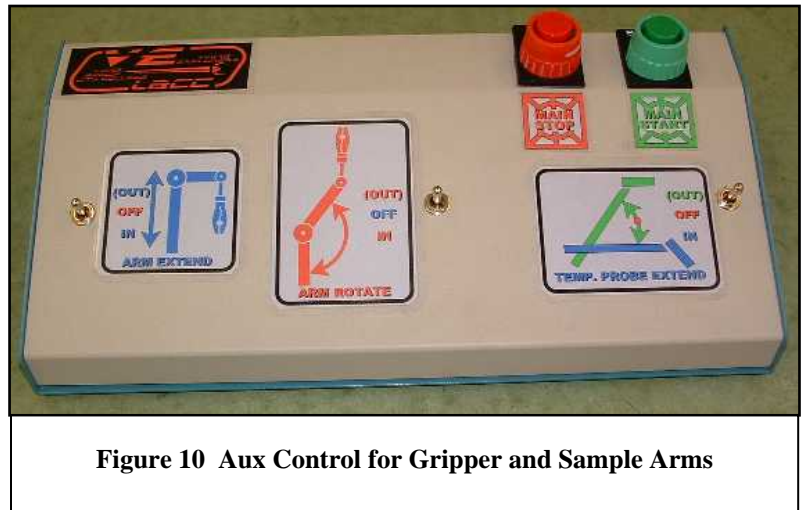

**Figure 10 Aux Control for Gripper and Sample Arms**

ADDITIONAL ROV PHOTOS



Figure 11 - Surface Power Sources

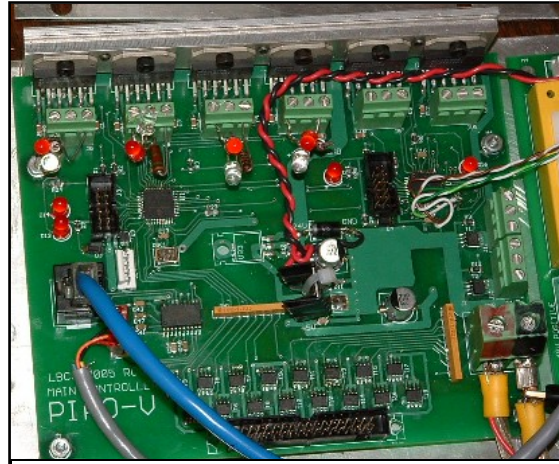

Figure 13 H-Bridge And PIC18F4431 Controller

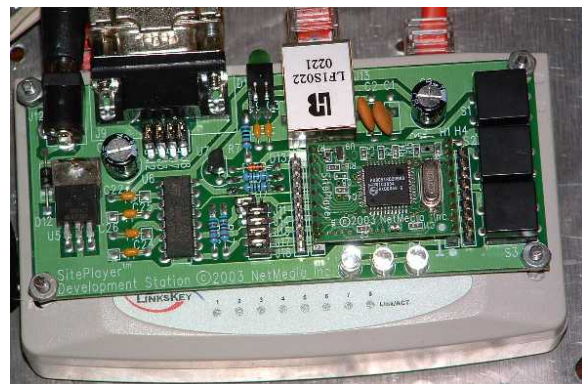

Figure 14 Telemetry Web Server on 8 Port Switch

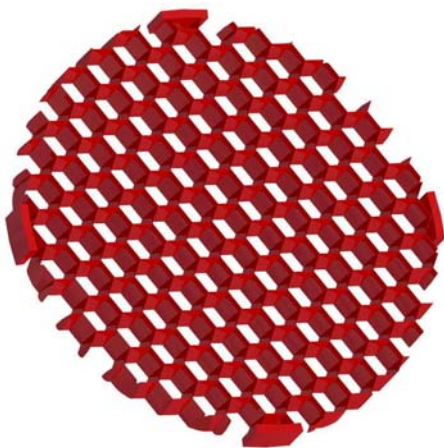

Figure 12 SolidWorks Drawing of Thruster Grill



Figure 15 Luxeon LED on Gripper

### Description of at least one challenge

While the Long Beach City College ROV team was working to build the VE II, we came across quite a challenge. The critical feature here is the method used to put the fiber optic connector in place and retrieve the data pods. The first idea was to use a motorized screw arm mechanism mounted on the end of a pneumatic cylinder. The cylinder would extend the screw out into place. At the end of the screw would be a straight probe to “stab” the data pods.

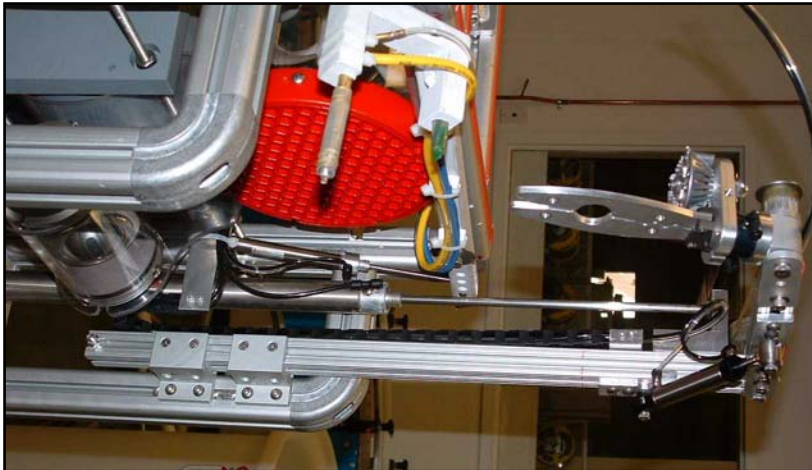

Figure 16 View of Gripper from Bottom

There were concerns about the strength, durability and the ability to successfully build this design. Also included in the concerns was keeping the overall size of the ROV within the required envelope. Finally, the screw design had a limitation of requiring the ROV to be directly in front of the part being picked up. The first idea of the screw arm was, bulky, and very sluggish.

We went into a redesign effort and researched a new arm and gripper assembly. We soon discovered that using all pneumatics was the way to go. After using the pneumatics for the gripper, we found that pneumatics was going to be useful for a number of features on the ROV.

Pneumatics is very quick and efficient and provides a reasonably strong grip. The whole arm fixture was redesigned. The VE II can now hover and is capable of extending its arm out from the bottom of the frame. This will permit the VE II to grab things from tight spaces. The redesigned arm gives us a 58cm reach out in front of the ROV and is quite flexible in its angle of attack for the pickup of the desired items.

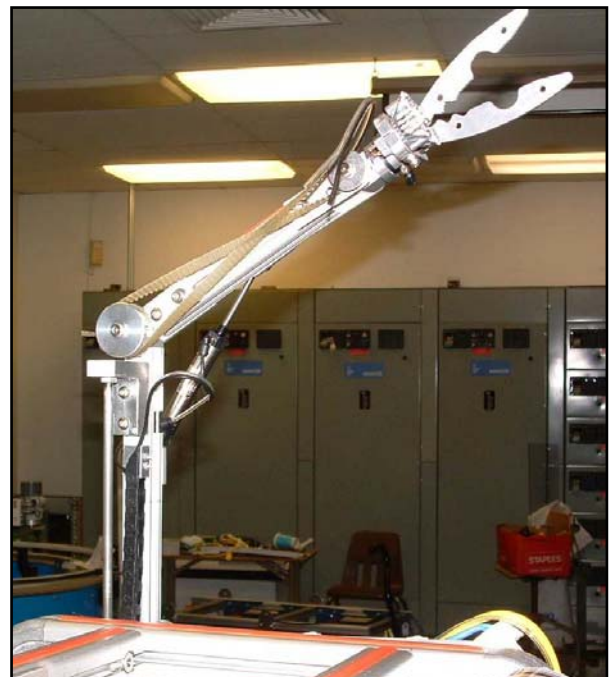

Figure 17 View of Gripper Extended

### Explanation of Troubleshooting Techniques.

One of the difficulties we had in the construction of this year's ROV was our new cameras. Having the capability to pan and tilt was great for our viewing but the wiring and creation of the connectors gave us a bit of trouble. Since we were using Cat5 network wires, the order that they went into the connectors was essential to its ability to function to our expectations. One of the problems we ran into was that one of the connectors was wired incorrectly on one camera. To locate the camera that wasn't working properly, we individually wired each camera to the board with the telemetry and picked the one that didn't show up on the screen. From then on finding the problem was quite easy because we used a simple technique of dividing the possible areas of where the error could be narrowing the areas until the problem was found. Since the output was easily accessible we rewired the outside connector and saw that this did not fix the operation of the camera and deduced that it was on the input side. This minor problem resulted in us having to take the camera out of its clear and sealed cylindrical container. Once open, we saw that two of the connector wires had come loose which one of us took care of immediately. We then tested the camera before placing it back in the cylinder and saw that it was working properly now that the connector was fixed. It was tested again after sealing it back up.

Before all the testing of the cameras could be completed, we had to make sure that they would be able to start-up initially which is the next problem that we came upon. The 700mA supply that we were using to bench test the four cameras couldn't handle the initialization current. When operating the motors, they take 300mA per camera and since the initialization causes all four motors to pan, tilt and rest on the home position, it became evident that 700mA wasn't enough to start the cameras. After replacing the bench supply with one with higher capacity, we were able to successfully test all four cameras. Our on board supply provides a current capacity of 1.5 amps for two cameras with a surge of up to 3 amps and we have two of these supplies on board.



**Figure 18 All Four Ethernet Cameras in Housings**

**Description of at least one lesson learned or skill gained** during the design and building process.

There were many valuable skills and lessons learned in the designing and construction of the VEII ROV. One such lesson came along when designing a part that would mount the acrylic cylinders for the vertical thrusters and at the same time seal the gap in the cylinders to prevent the flow of water from exiting out the side of the cylinders. A part was designed that fit perfectly, one could say too perfect. We used rapid prototyping to make the part. Only when we attempted to put the part onto our ROV we discovered two major flaws. Our first problem was that the welded beading on one of the motor mounts was not taken into account and got in the way. The second problem was the two weak points that were too thin for ABS plastic and easily broke while mounting the part. The part was redesigned with gussets to strengthen the part and two gutters were carved out to make space for the weldments. The new part was plenty strong for the application and fit like a glove. We learned that anything can be designed, but in reality not everything will work. You must keep in mind tolerances, function, and material. Realize that there are limits in the real world.

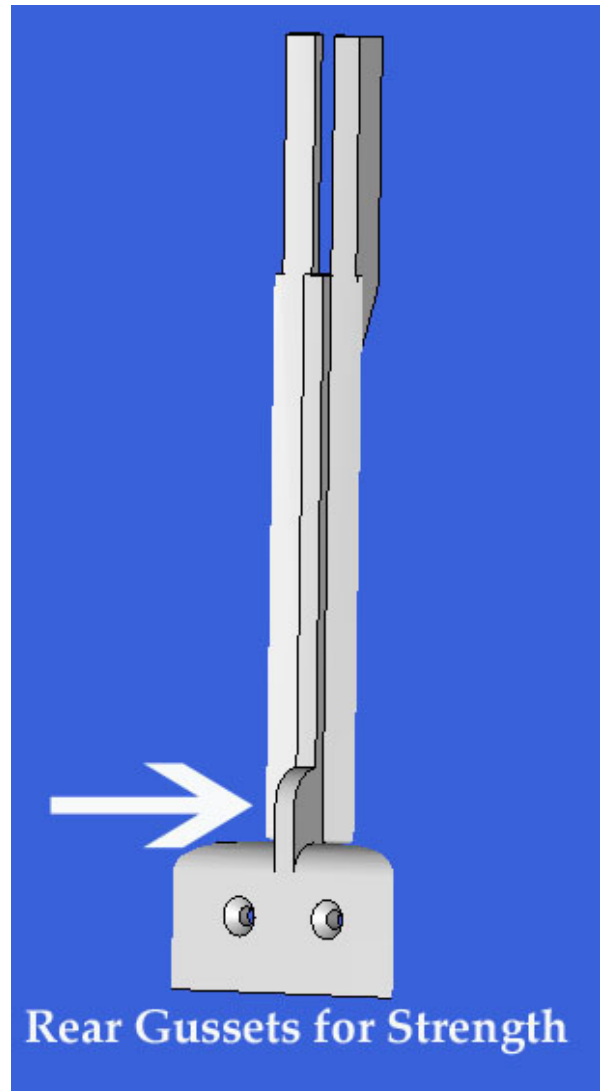
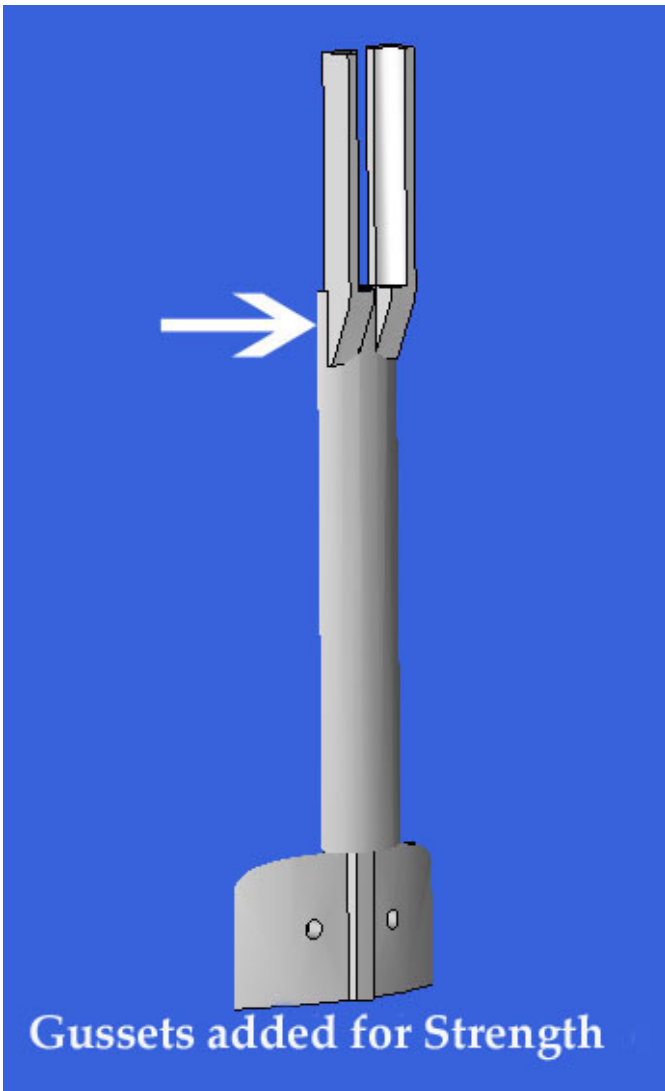

## Electrical schematic – Surface Controls

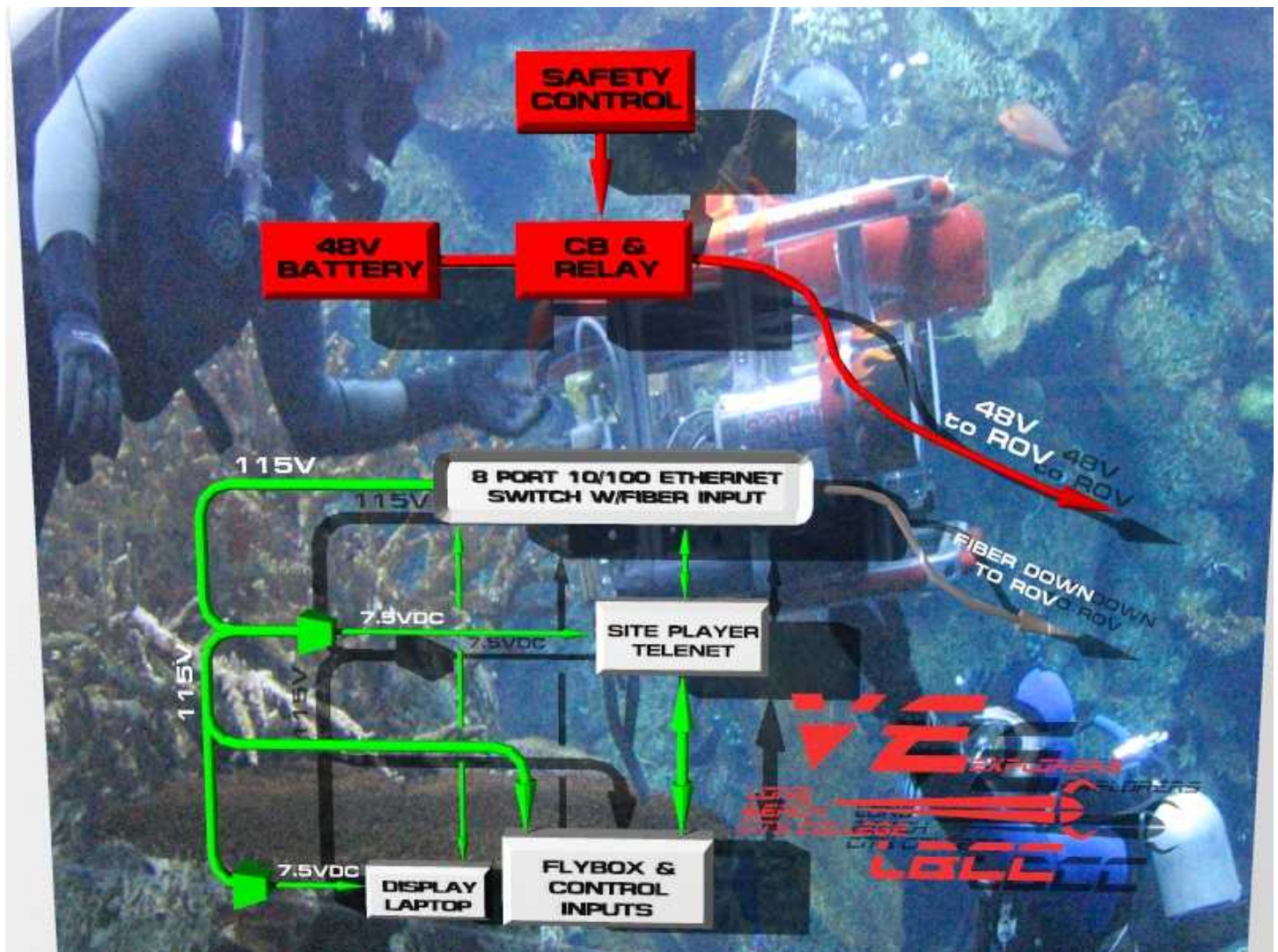

ROV SURFACE SCHEMATIC DIAGRAM

## Components

- 48V DC Source – Four 12V batteries in series
- Safety Control, Operator initiated shutdown/control of power from console. One button kills all power, both electrical and pneumatic.
- Power to ROV via four 12ga wires.
- Communication systems with Fiber Optic Cable
- Ethernet 10/100 Mbit switch for surface with fiber optic interface.
- Flybox (joystick) controller with digital inputs to control ROV.
- PC compatible laptop for display of video and telemetry

- Electrical schematic – ROV Controls

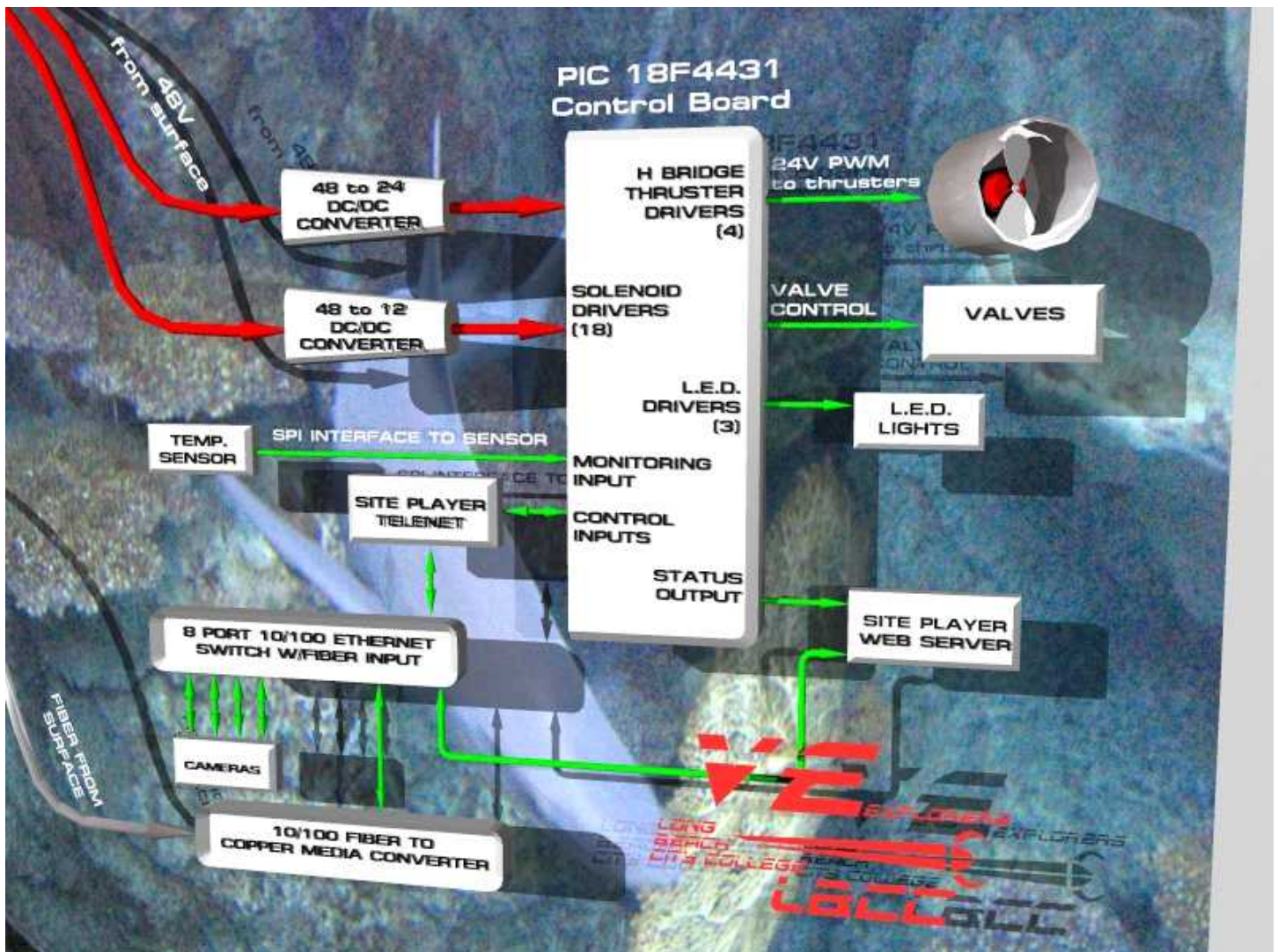

## ROV ELECTRICAL CONTROL SCHEMATIC

### Components

- 48V DC-DC Converters. 24V & 12V outputs. Input Range 36 to 75 Volts. Eliminates voltage drop problems.
- Digital Temperature Sensor, accuracy  $\pm 0.5^{\circ}\text{C}$ . No calibration needed.
- Thrusters controlled with integrated PWM H-Bridge chips.
- Lights are high output single Luxeon LEDs driven by 700mA current sources.
- Controller board with H-Bridges and 18 MOSFET valve drivers.
- Two – 18F4431 PIC processors on controller board.
- 8 port Ethernet 10/100 Mbit switch with fiber optic interface.
- Four Ethernet cameras with controllable Pan and Tilt functions.
- Built in Web Server for telemetry display

Pneumatics schematic – ROV & Surface

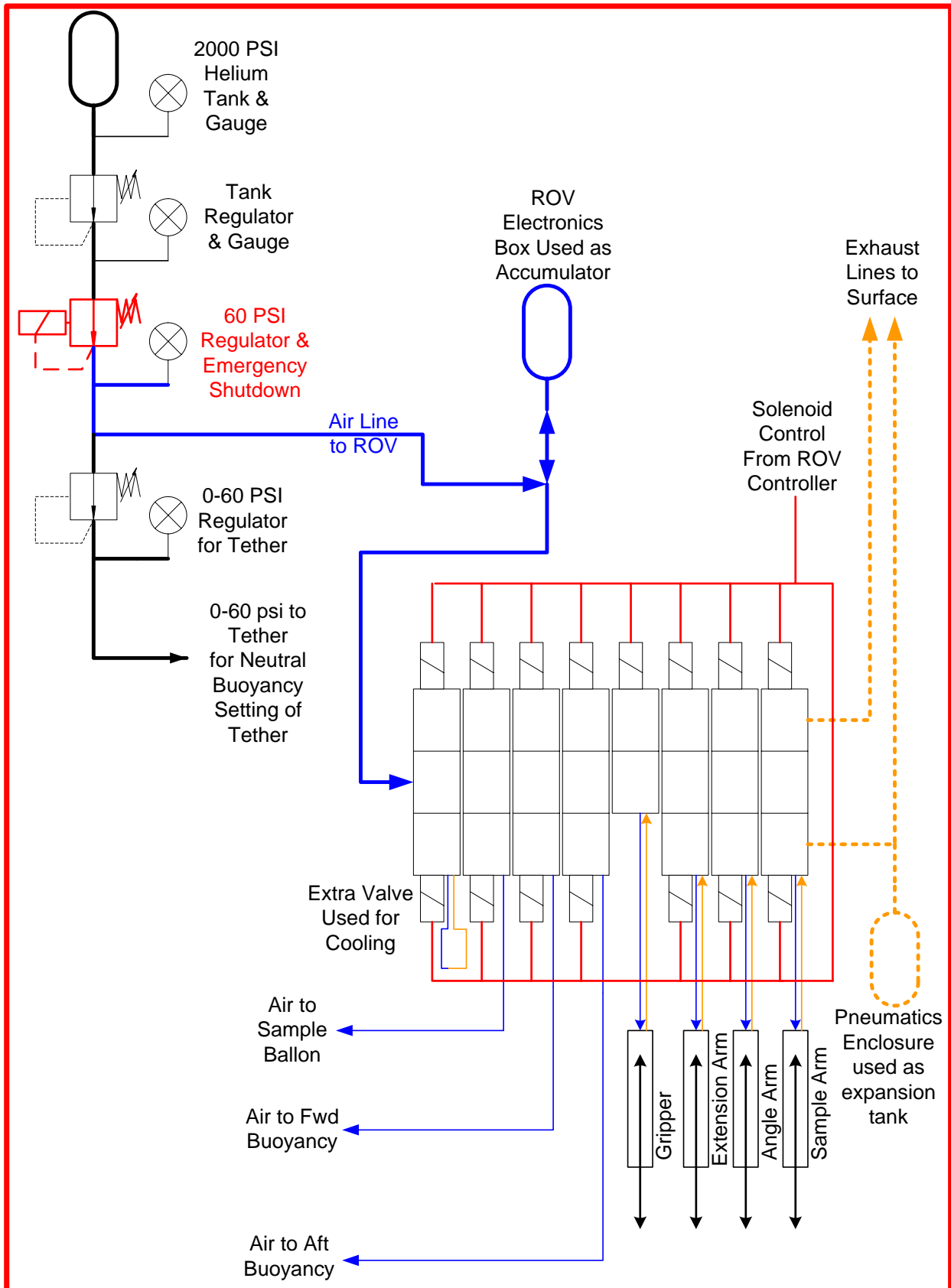

## LBCC 2005 ROV Expense Report

Date	Type	Description	Amount	Balance	Donations
01-Jan-05	CarryOver	Left over Funds from Previous Years Fund raising	\$3,974.00	\$3,974.00	
01-Jan-05	Deposit	Starting Funds from MATE	\$100.00	\$4,074.00	
10-Jan-05	Expense	Circuit Boards (Operating + 2 spares)	(\$267.65)	\$3,806.35	
12-Jan-05	Expense	Electronics Parts (for 3 sets of boards)	(\$376.12)	\$3,430.23	
12-Mar-05	Expense	Wheeled Wagon for Support Cart	(\$54.11)	\$3,376.12	
17-Mar-05	Expense	Power Supply Modules	(\$373.00)	\$3,003.12	
22-Mar-05	Expense	Camera	(\$133.50)	\$2,869.62	
23-Mar-05	Expense	Camera	(\$161.61)	\$2,708.01	
30-Mar-05	Expense	Camera O-Ring Seals	(\$15.76)	\$2,692.25	
30-Mar-05	Expense	Cast Acrylic for Cameras & Thrusters	(\$160.38)	\$2,531.87	
30-Mar-05	Expense	Stainless Hardware	(\$24.89)	\$2,506.98	
04-Apr-05	Expense	Air Cylinders	(\$56.00)	\$2,450.98	
08-Apr-05	Expense	Gripper & Extrusions	(\$166.56)	\$2,284.42	
10-Apr-05	Expense	Camera	(\$112.50)	\$2,171.92	
11-Apr-05	Expense	Camera	(\$127.50)	\$2,044.42	
13-Apr-05	Expense	Stainless Hardware	(\$54.70)	\$1,989.72	
16-Apr-05	Expense	Stainless Hardware	(\$46.18)	\$1,943.54	
20-Apr-05	Expense	Pneumatic Supplies	(\$658.47)	\$1,285.07	
04-May-05	Deposit	Ebay Fund Raising Efforts	\$1,647.13	\$2,932.20	
05-May-05	Expense	Helium Tank and Filling	(\$148.30)	\$2,783.90	
06-May-05	Expense	Paint & Supplies	(\$28.56)	\$2,755.34	
11-May-05	Expense	Circuit Breaker, Wire & Heat Shrink Tubing	(\$54.48)	\$2,700.86	
11-May-05	Expense	Fiberglass, Resin & Foam	(\$72.69)	\$2,628.17	
13-May-05	Expense	Fiber Optic Supplies	(\$101.43)	\$2,526.74	
20-May-05	Deposit	Ebay Fund Raising Efforts	\$54.24	\$2,580.98	
Jan-05	Donation	Aluminum Extrusion			\$ 999.23
Jan-05	Donation	Plastic for Pneumatics housing and cart			\$ 500.00
Mar-05	Donation	Robotic Chain, Cable Protection			\$ 50.00
Mar-05	Donation	Welding Services			\$ 250.00
5-Mar	Donation	Machining Services			\$ 750.00
Mar-05	Donation	ABS Plastic for Printing thruster sheilds			\$ 100.00
Apr-05	Donation	Fiber Optic Switch & Media Converters			\$ 1,500.00
Apr-05	Donation	Multimode Fiber Optic Cable (100 feet)			\$ 175.00
Apr-05	Donation	6 LED Lamps			\$ 150.00
		Total Expenses	(\$3,194.39)		
		Total Donations	\$ 4,474.23		
		Total Fund Raising	\$5,775.37		

**NOTE: Expenses related to last year's ROV are not included. There were many items that we were able to reuse without incurring new costs. For instance, we were able to reuse the thrusters and the electronics enclosure.**

Discussion of Future Improvements

One area of future improvement for the ROV would be the inclusion of a standard serial bus such as the CAN Bus. Future expansion of the science package increases the number of sensors and actuators on the ROV. This creates problem with weight and the number of wires and connectors that have to be used to connect and operate all the systems. To keep the volume of wiring from becoming uncontrollable and the number of connectors on the ROV controller to a minimum, the ROV could use the CAN BUS system to avoid complicated wiring.



**CAN (Controller Area Network) Bus Interfaces** CAN Controller Area Network bus normally contains set of microcontrollers connected with 2-wire interface running over either: Shielded Twisted Pair (STP), Unshielded Twisted Pair (UTP), or Ribbon cable. Driver sends a signal by the bus and all of the receivers also called node listen for signal. All nodes can listen and transmit at the same time.

Data rate (message)

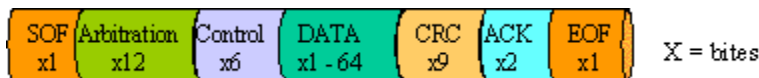

The two-wire differential serial CAN bus system can operate in noisy electrical environments with a high level of data integrity. This is very important in the ROV for proper measurements. The CAN bus also has an open architecture and is extremely flexible allowing users to define their own interface packages. It is capable of high-speed (1 Mbits/s) in distances that you would expect in an ROV. The CAN bus is highly fault tolerant, with powerful error detection and handling designed in. Developed by Bosch in Germany, CAN was originally designed specifically for the automotive market, today it has branched out to numerous other industries.

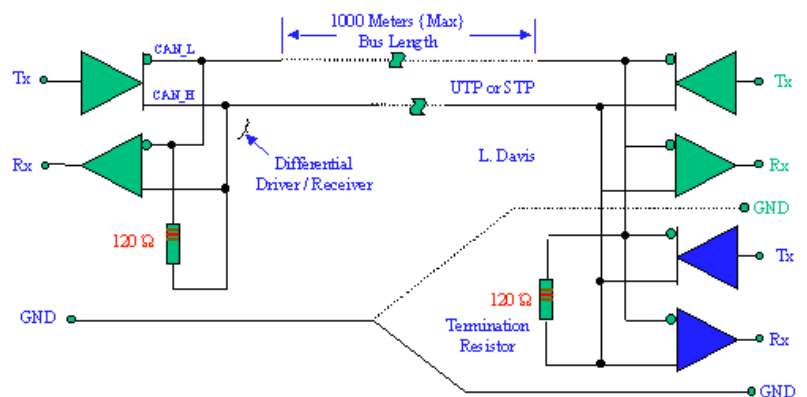

SOURCES:

- <http://www.interfacebus.com>
- <http://sine.ni.com>
- <http://www.semiconductors.philips.com>

## Jet Propulsion Laboratory, Pasadena CA

Jet Propulsion Laboratory is located in Pasadena CA. JPL's one main goal and function is space exploration. Jet Propulsion Lab officially got their name from the United States Army in November 20 1943. JPL was a part of Caltech Pasadena Aeronautical Laboratory. JPL does not limit their exploration to outer space it also has missions to explore our home planet earth. JPL has also designed some satellites that can take water temperatures from the ocean and has found lost cities in Cambodia using of visible and infrared imaging.

JPL in addition designs planetary rovers to explore the planet Mars. In order to do so the people at JPL had to create a test world environment similar to Mars. They have an indoor testing area and have also used the desert for testing the rovers. The rovers were made to survey and take rock sample on the surface of the planet. Though the rovers create their own power through solar panels, they still rely on the communication link from the home base to operate. This makes it very similar to an underwater ROV which relies on a tether for operation orders.



Similar to the way JPL tests their rovers, we at Long Beach City College have several test stations for our ROV. We have utilized the Aquarium of the Pacific as one of our testing facilities. Our other 2 testing facilities are our school pool and our personal 3.8k-liter test tank. In this tank we are able to simulate the type of light that might be available on Europa. JPL built into the software of its rovers a failsafe mode called "cripple" mode. This allows them to override the normal operating system and get around problems. In our ROV we also have a failsafe built into the tether. In case there is a problem with the fiber optic connection, we have an extra

cat5e cable as a fallback option for communication. The JPL rovers are collecting dirt samples, and evidence of an ancient Martian sea. We will be using our ROV to gather temperature readings, collect water samples while we navigate and explore.

With all this experience we are getting designing and building an operational ROV, a career with an institution like JPL is a natural for us and is only a few steps away.

### Citations

<http://www.jpl.nasa.gov/>

[http://www.jpl.nasa.gov/about\\_JPL/jpl101.pdf](http://www.jpl.nasa.gov/about_JPL/jpl101.pdf)

<http://marsrovers.jpl.nasa.gov/home/index.html>



Acknowledgements

The LBCC Viking Explorer ROV Team would like to acknowledge the following for their contributions and help with this project.

